



## Fingerprint Lock

### F022

Used in drawer and cabinet in hospital, office, school etc.



Fingerprint



High sensitivity



Wide range of use



>4000 HOUR

Low power design



F022B



F022W

## Accessory parameters



**LOCK CASE**  
Material:ABS  
Size:  
60×86×23.5mm



**STRIKING PLATE**  
Material:ABS  
Size:  
73.3X24.2X12MM



**SCREW**  
M4×25 (Panel)  
ST3.5×16(Lock case)  
ST3.5×20(Striking Plate)



**CONNECTING WIRE**

## technical parameter

- Model: F022
- Color: black, white
- Material: zinc aluminum alloy
- Battery: 3xAAA battery
- Supply voltage: 4.5V
- Quiescent current:  $\leq 20\mu\text{A}$
- Dynamic current:  $\leq 220\text{mA}$
- Low voltage alarm voltage:  $3.6\text{V} \pm 0.2\text{V}$
- Life time: >20,000 times opening
- Working temperature:  $0^{\circ}\text{C}-55^{\circ}\text{C}$
- Working humidity: 20%-80% RH

## Features

- Smart and keyless, fingerprint control.
- Up to 20 fingerprints can add.
- The power supply uses 3xAAA battery.
- Low-power design, life time more than 1 year.
- Low battery warning, Micro USB for low battery.
- Motorized mechanism automatically.
- Suitable for installation in drawer cabinets, single door, double door and other wooden cabinets.
- Door thickness requirement >5mm, standard screw for 15-20mm Door panel.

## Installation size

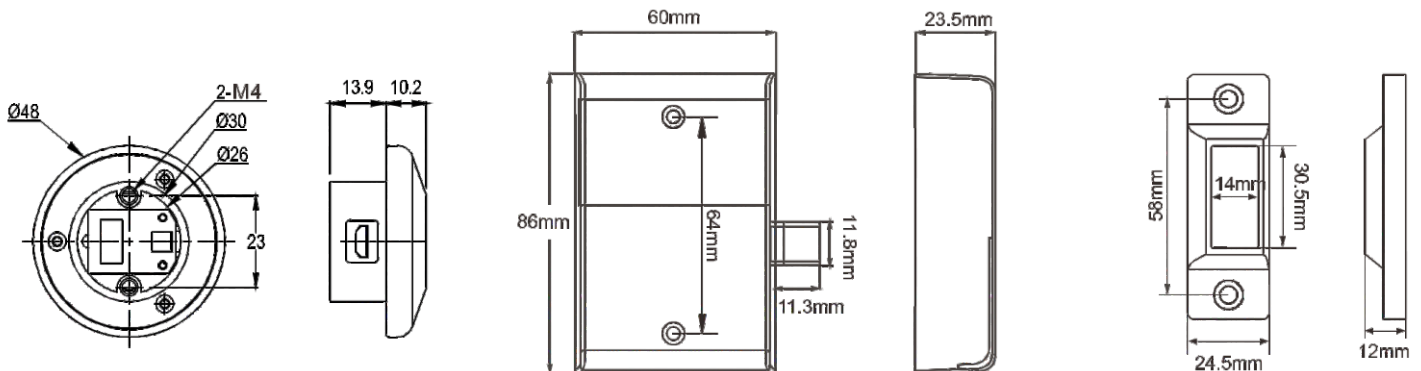

PANEL

LOCK CASE

STRIKING PLATE